

## ACS 751 (Hybrid)



**BOSCH**

de Ersatzteilliste      fr Liste de recambio  
en Spare part list      es Lista de piezas por separado

Bezeichnung Designation Dénomination Designación	Bestellnummer Partnumber Référence Núm.depedido	Gefertigt von Production since fabrication de fabricación de	Gefertigt bis produced until fabrication fabricación	Ersatzteilkpflicht bis Service part obligation Obligation de pièce de rechange Obligación de disp. de piezas de recambio	Bemerkungen Notes Notes Notas
ACS 751 (Hybrid)	F 002 DG0 414	04/2011	08/2012		230 V
ACS 751 (Hybrid)	F 002 DG0 4AA	01/2012			Hybrid, 230 V

Class	----- de -----	----- en -----	----- fr -----	----- es -----	----- it -----
●	<b>Verschleißteil:</b> <b>Definition:</b> Zu erwartende Lebensdauer des Teiles ist kleiner als die zu erwartende Lebensdauer des Produktes!  - Bei Ausfall nicht mehr funktionsfähig oder sicherer Einsatz des Produktes nicht mehr gewährleistet - Verminderte Gewährleistung - Wir empfehlen, diese Ersatzteile im lokalem Lager zu bevorraten.  Hinweis: Der Verschleiß und das Wartungsintervall sind abhängig von: - der Einsatzzeit - Art und Häufigkeit der Verwendung - Alter der Maschine	<b>Wearing part:</b> <b>Definition:</b> The expected lifetime of the part is shorter than the expected lifetime of the product!  - In the event of failure, no longer functional or safe use of product no longer guaranteed - Reduced warranty - We recommend stocking these replacement parts in the local warehouse.  Note: Wear and the maintenance interval depend on: - Usage time - Nature and frequency of use - Age of machine	<b>Pièce d'usure :</b> <b>Définition :</b> La durée de vie prévisible de la pièce est inférieure à la durée de vie prévisible du produit !  - Plus en ordre de marche en cas de panne ou utilisation sûre du produit plus garantie - Garantie réduite - Nous conseillons d'avoir ces pièces de rechange en réserve dans un entrepôt local.  Remarque : L'usure et l'intervalle d'entretien dépendent des facteurs suivants : - durée d'utilisation - nature et fréquence de l'utilisation - âge de la machine	<b>Pieza de desgaste:</b> <b>Definición:</b> La vida útil esperada de la pieza es menor que la vida útil esperada del producto.  - En caso de avería ya no está en condiciones de funcionar o el uso seguro del producto ya no se garantiza - Garantía reducida - Se recomienda almacenar esas piezas de recambio en un almacén local.  Nota: El desgaste y el intervalo de mantenimiento dependen: - del tiempo de servicio - del tipo y frecuencia de uso - de la edad de la máquina	<b>Parte soggetta a usura:</b> <b>Definizione:</b> Il ciclo di vita prevedibile del componente è inferiore al ciclo di vita prevedibile del prodotto.  - In caso di avaria il prodotto non è più in grado di funzionare oppure non ne è più garantita la sicurezza d'impiego - Garanzia ridotta - Consigliamo di tenere una scorta di questi ricambi nel magazzino ocale.  Avvertenza: l'usura e l'intervallo di manutenzione dipendono da: - tempo operativo - tipo e frequenza dell'impiego - età della macchina
ⓘ	<b>Funktionsteil:</b> <b>Definition:</b> Die zu erwartende Lebensdauer des Teiles ist gleich oder größer als die zu erwartende Lebensdauer des Produktes!  - Bei Ausfall nicht mehr funktionsfähig oder sicherer Einsatz des Produktes nicht mehr gewährleistet - Standard Gewährleistung - Wir empfehlen, diese Ersatzteile im lokalem Lager zu bevorraten.	<b>Function part:</b> <b>Definition:</b> The expected lifetime of the part is the same as or longer than the expected lifetime of the product!  - In the event of failure, no longer functional or safe use of product no longer guaranteed - Standard warranty - We recommend stocking these replacement parts in the local warehouse.	<b>Pièce fonctionnelle :</b> <b>Définition :</b> La durée de vie prévisible de la pièce est égale ou supérieure à la durée de vie prévisible du produit !  - Plus en ordre de marche en cas de panne ou utilisation sûre du produit plus garantie - Garantie standard - Nous conseillons d'avoir ces pièces de rechange en réserve dans un entrepôt local.	<b>Pieza funcional:</b> <b>Definición:</b> La vida útil esperada de la pieza es igual o mayor que la vida útil esperada del producto.  - En caso de avería ya no está en ndiciones de funcionar o el uso seguro del producto ya no se garantiza - Garantía estándar - Se recomienda almacenar esas piezas de recambio en un almacén local.	<b>Parte funzionale:</b> <b>Definizione:</b> Il ciclo di vita prevedibile del componente è uguale o superiore al ciclo di vita prevedibile del prodotto.  - In caso di avaria il prodotto non è più in grado di funzionare oppure non ne è più garantita la sicurezza d'impiego - Garanzia standard - Consigliamo di tenere una scorta di questi ricambi nel magazzino locale.
○	<b>Nicht-Funktionsteil:</b> <b>Definition:</b> Die zu erwartende Lebensdauer des Teiles ist größer als die zu erwartende Lebensdauer des Produktes!  - Bei Ausfall weiterhin funktionsfähig und ein sicherer Einsatz des Produktes ist gewährleistet - Standard Gewährleistung - Wir empfehlen, diese Ersatzteile bei einem Bedarf über das Zentrallager zu bestellen.	<b>Non-function part:</b> <b>Definition:</b> The expected lifetime of the part is the same as or longer than the expected lifetime of the product!  - In the event of failure, still functional and safe use of the product is guaranteed - Standard warranty - We recommend ordering these replacement parts as required via the central warehouse.	<b>Pièce non fonctionnelle :</b> <b>Définition :</b> La durée de vie prévisible de la pièce est égale ou supérieure à la durée de vie prévisible du produit !  - Toujours en ordre de marche en cas de panne et utilisation sûre du produit garantie - Garantie standard - Nous recommandons de commander ces pièces de rechange au besoin par le biais de l'entrepôt central.	<b>Pieza no funcional:</b> <b>Definición:</b> La vida útil esperada de la pieza es igual o mayor que la vida útil esperada del producto.  - En caso de avería aún en condiciones de funcionar y el uso seguro del producto se garantiza - Garantía estándar - Se recomienda pedir esas piezas de recambio al almacén central, en caso de necesidad.	<b>Parte non funzionale:</b> <b>Definizione:</b> Il ciclo di vita prevedibile del componente è uguale o superiore al ciclo di vita prevedibile del prodotto.  - In caso di avaria il prodotto continua ad essere in grado di funzionare e ne rimane garantita la sicurezza d'impiego - Garanzia standard - Consigliamo di ordinare questi ricambi in caso di necessità attraverso il magazzino centrale.

Intervall	Wartungsintervall des Verschleißteiles	Maintenance intervall for wearing part	Intervalle d'entretien de la pièce d'usure	Intervalo de mantenimiento de la pieza de desgaste	Intervallo di manutenzione della parte soggetta a usura
h	Stunden	hours	heures	Horas	ore
d	Tage	days	jours	Días	giorni
m	Monate	month	mois	Meses	mesi
cy	Zyklen	cycles	cycles	Ciclos	cicli
-	ohne definiertes Wartungsintervall	No defined maintenance interval	pas d'intervalle d'entretien défini	Sin intervalo de mantenimiento definido	senza intervallo di manutenzione definito

Customer	Austausch des Teiles durch den Kunden (Werkstatt)	Replacement of part by customer (workshop)	Remplacement de la pièce par le client (atelier)	Sustitución de la pieza por el cliente (taller)	La sostituzione del componente da parte del cliente (officina)
-	ist nicht erlaubt.	Not permissible.	pas autorisé	no está permitida.	non è ammessa.
x	ist erlaubt (Diese Ersatzteile sind auch in der Betriebsanleitung aufgeführt)	Permissible (these replacement parts are also listed in the operating instructions)	autorisé (ces pièces de rechange sont également indiquées dans la notice)	está permitida (estas piezas de recambio también se indican en las instrucciones de	è ammessa (questi ricambi sono riportati anche nelle istruzioni d'uso)

Part-number	Bestellnummer des Ersatzteiles oder Verweis auf ein Standardteil	Order number of replacement part or reference to standard part	Référence de commande de la pièce de rechange ou signalement de pièce normalisée	Número de pedido de la pieza de recambio o nota sobre la pieza normalizada	Codice di ordinazione del ricambio o avvertenza sul componente unificato
Normpart	<b>Normteil:</b> Ersatzteile, die normalerweise über unterschiedliche Kanäle bezogen werden können wie z. B. Schrauben, Mutttern, O-Ringe, Tintenpatronen. Alle 3 Ersatzteil-Kategorien (siehe Class) sind möglich	<b>Normpart (Standard part):</b> Replacement parts which can normally be obtained through various channels e.g. bolts, nuts, O-rings, ink cartridges. All 3 replacement part categories (refer to Class) are possible	<b>Pièce normalisée :</b> Pièces de rechange qui peuvent normalement être obtenues par le biais de différents canaux, par ex. les vis, écrous, joints toriques, cartouches d'encre. Les 3 catégories de pièces de rechange (voir Class) sont possibles	<b>Pieza normalizada:</b> Piezas de recambio que se pueden adquirir normalmente a través de diferentes vías, p. ej., tornillos, tuercas, anillos de sección circular, cartuchos de tinta. Las tres categorías de piezas de recambio (véase clase) son posibles.	<b>Parte unificata (componente unificato):</b> Si tratta di ricambi che in genere possono essere acquistati attraverso diversi canali, come ad es. viti, dadi, O-ring, cartucce di inchiostro. Sono possibili tutte e 3 le categorie di ricambi (vedi Class)

Pos.	Class	Intervall	Customer	Partnumber	BEZEICHNUNG (de)	IDENTIFICATION (fr)	Drawing
					IDENTIFICATION (en)	IDENTIFICACION (es)	
					Kommentar (de)	Comment (en)	
1	○	-	X	F002DG1634	Abdeckblende	Cache De Recouvrement	
					Cover Panel	Revestimiento	
					Top panel		
2	●	-	X	F002DG1637	Abdeckblende	Cache De Recouvrement	
					Cover Panel	Revestimiento	
3	○	-	X	F002DG1635	Service hatch - right side		
					Abdeckblende	Cache De Recouvrement	
4	○	-	X	F002DG1631	Cover Panel	Revestimiento	
					Side panel - right side		

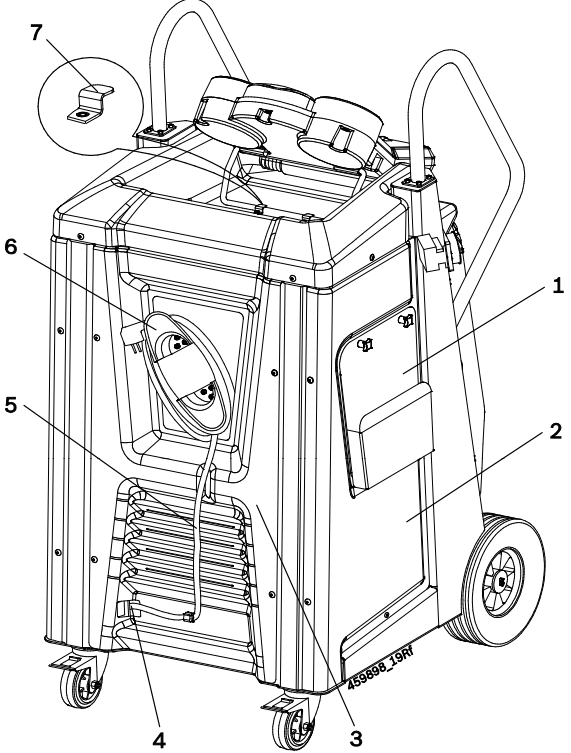
Pos.	Class	Intervall	Customer	Partnumber	BEZEICHNUNG (de)	IDENTIFICATION (fr)	Drawing
					IDENTIFICATION (en)	IDENTIFICACION (es)	
					Kommentar (de)	Comment (en)	
1	●	-	X	F002DG1638	Abdeckblende	Cache De Recouvrement	
					Cover Panel	Revestimiento	
					Service hatch - left side		
2	○	-	X	F002DG1633	Abdeckblende	Cache De Recouvrement	
					Cover Panel	Revestimiento	
3	○	-	X	F002DG1636	Abdeckblende	Cache De Recouvrement	
					Cover Panel	Revestimiento	
4	●	-	-	F002DG1618	Leitungssteckdose	Prise Femelle De Cable	
					Cable Socket	Base De Enchufe P. Cable	
5	●	-	X	1684461106	Netzanschlussleitung	Câble d alimentation	
					Power supply cord	Linea De Conexion A Red	
6	○	-	-	F002DG19G5	Seilhalter	Fixation De Cable	
					Cable Holder	Soporte De Cable	
7	○	-	-	F002DG14G4	Verriegelungselement		
					Locking element		

Pos.	Class	Intervall	Customer	Partnumber	BEZEICHNUNG (de)	IDENTIFICATION (fr)	Drawing
					IDENTIFICATION (en)	IDENTIFICACION (es)	
					Kommentar (de)	Comment (en)	
1	●	-	-	F002DG1528	Led-Display	Affichage A Led	
					Led Display	Visualisad Diode Lumin Led	
2	●	-	-	F002DG1532	Druckmesser	Manometre	
					Pressure Gauge	Manometro	
3	●	-	-	F002DG1599	Low-pressure gauge		
					Tastatur	Clavier A Touches	
4	●	-	-	F002DG1600	Keyboard	Teclado	
					Druckermodul	Module Imprimante	
5	●	-	X	F002DG1450	Printer Module	Módulo De Presión	
					Papierrolle	Bobine De Papier	
6	●	-	-	F002DG1529	Paper Reel	Bobina De Papel	
					Druckmesser	Manometre	
7	●	-	-	F002DG1601	Pressure Gauge	Manometro	
					Lcd-Anzeige	Indicateur A Diodes "Lcd"	
8	●	-	-	F002DG1598	Lcd-Display	Indicacion "Lcd"	
					Leiterplatte	Circuit Imprime	
					Printed Circuit Board	Tarjeta Circ Impreso	
					HMI board		

Pos.	Class	Intervall	Customer	Partnumber	BEZEICHNUNG (de)	IDENTIFICATION (fr)	Drawing
					IDENTIFICATION (en)	IDENTIFICACION (es)	
					Kommentar (de)	Comment (en)	
1	●	-	-	F002DG14A6	Verteilerblock	Collecteur	
					Manifold	múltiple	
					Manifold top block only		
2	●	-	-	F002DG1596	Magnetventil	Électrovalve	
					Solenoid Valve	Electrovalvula	
3	●	-	X	F002DG1534	Filtersatz	Jeu De Filtres	
					Filter Set	Juego De Filtros	
					Set of filter drier and two inline filters		

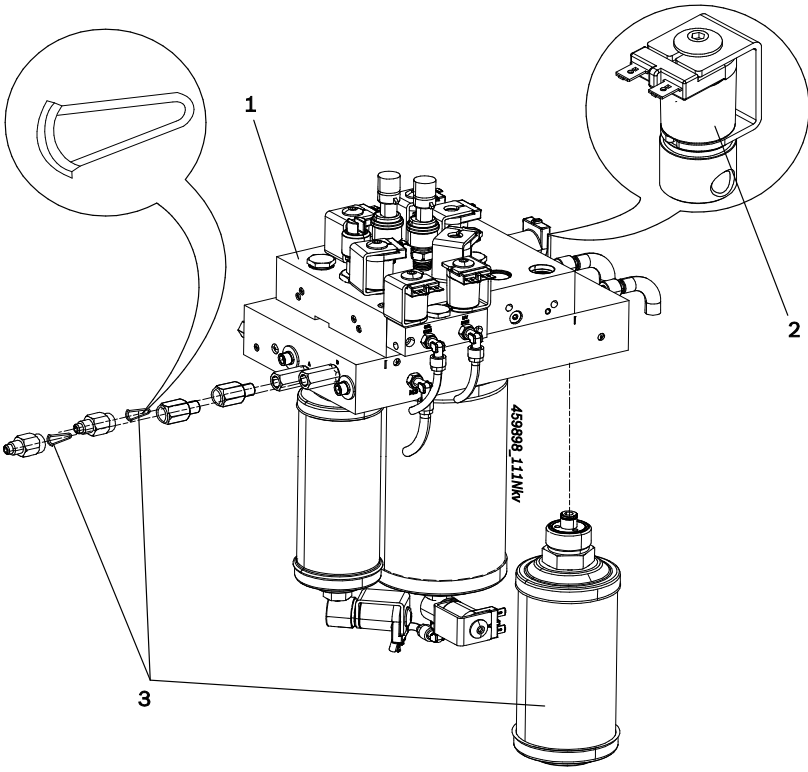

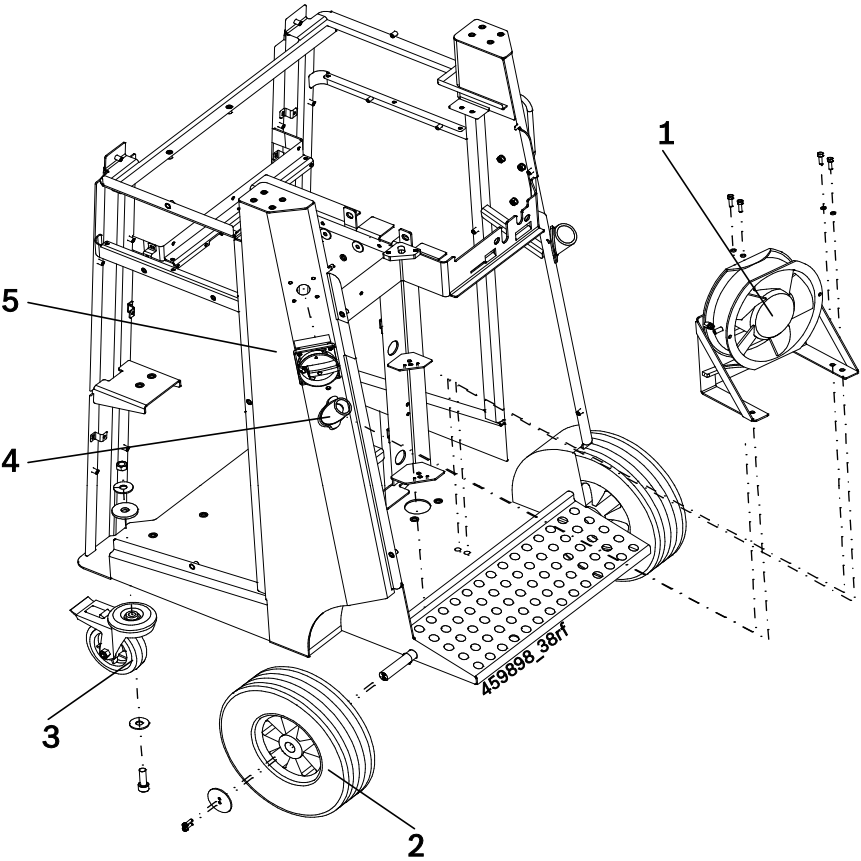
Pos.	Class	Intervall	Customer	Partnumber	BEZEICHNUNG (de)	IDENTIFICATION (fr)	Drawing
					IDENTIFICATION (en)	IDENTIFICACION (es)	
					Kommentar (de)	Comment (en)	
1	●	-	-	F002DG1630	Lüfter	Ventilateur	
					Fan	Ventilador	
2	●	-	-	F002DG1537	Rad	Roue	
					Wheel	Rueda	
					Set of front wheels		
	3	●	-	F002DG1536	Rad	Roue	
Wheel					Rueda		
					Set of rear wheels		
	4	●	-	F002DG1546	Tülle	Manchon	
Grommet					Ojete protector		
5	●	-	F002DG1602	Taster	Palpeur		
				Switch	Palpador		



Pos.	Class	Intervall	Customer	Partnumber	BEZEICHNUNG (de)	IDENTIFICATION (fr)	Drawing
					IDENTIFICATION (en)	IDENTIFICACION (es)	
					Kommentar (de)	Comment (en)	
1	●	-	-	F002DG1603	Tank	Réservoir	
					Tank	Tanque	
					Internal refrigerant cylinder		
2	●	-	-	F002DG1606	Waage	Balance	
					Balance	Balanza	
					Load cell for internal refrigerant tank		
3	●	-	-	F002DG1607	Luftabscheider	Purgeur D'air	
					Air Eliminator	Separador De Aire	
					Air purge valve		
4	●	-	-	F002DG1608	Temperaturfühler	Sonde De Temperature	
					Temperature Sensor	Sonda Termica	
5	●	-	X	F002DG1650	Justiergewicht	Poids D'etalonnage	
					Calibration Weight	Pesa De Contraste	
					6 kg		

Pos.	Class	Intervall	Customer	Partnumber	BEZEICHNUNG (de)	IDENTIFICATION (fr)	Drawing
					IDENTIFICATION (en)	IDENTIFICACION (es)	
					Kommentar (de)	Comment (en)	
1	●	-	-	F002DG14F4	Verschlusschraube Screw Plug With O-ring	Bouchon Filete Tapon Roscado	
2	●	-	-	F002DG1542	Vakuumpumpe Vacuum Pump	Pompe à Vide Bomba De Vacio	
3	●	-	-	F002DG1609	Verdichter Compressor	Compresseur Compresor	

Pos.	Class	Intervall	Customer	Partnumber	BEZEICHNUNG (de)	IDENTIFICATION (fr)	Drawing
					IDENTIFICATION (en)	IDENTIFICACION (es)	
					Kommentar (de)	Comment (en)	
1	●	-	-	F002DG1583	Schlauch	Tuyau	
					Hose	Manguera	
					PA12 hose - For compressor, 8x6/3000 mm. Color: White		
2	●	-	-	F002DG1408	Schlauch	Tuyau	
					Hose	Manguera	
Silicon rubber hose - Valve block to fresh oil, 6x4/2500 mm. Transparent							
3	●	-	-	F002DG1639	Schlauch	Tuyau	
					Hose	Manguera	
PA11 hose, 4x2/3000 mm. Color: Black							
4	●	-	-	F002DG1407	Schlauch	Tuyau	
					Hose	Manguera	
Set of HP and LP hoses							
5	●	-	-	F002DG1557	Schlauch	Tuyau	
Hose							
PA12 hose for vacuum pump. Color: Black							
6	●	-	-	F002DG1409	Schlauch	Tuyau	
					Hose	Manguera	
PA 11 hoses, 2 x 4 x 3000 mm, HP. Color: Translucent white							

Pos.	Class	Intervall	Customer	Partnumber	BEZEICHNUNG (de)	IDENTIFICATION (fr)	Drawing
					IDENTIFICATION (en)	IDENTIFICACION (es)	
					Kommentar (de)	Comment (en)	
1	●	-	X	F002DG1610	Kunststoffbehälter	Conteneur Plastique	
					Plastic Container	Recipiente De Plastico	
				Standard bottle for UV dye			
2	●	-	X	F002DG14B8	Kunststoffbehälter	Conteneur Plastique	
					Plastic Container	Recipiente De Plastico	
				Standard bottle for POE oil			
2-1	●	-	X	F002DG1610	Kunststoffbehälter	Conteneur Plastique	
					Plastic Container	Recipiente De Plastico	
				Standard bottle for PAG oil			
3	●	-	X	F002DG1611	Kunststoffbehälter	Conteneur Plastique	
					Plastic Container	Recipiente De Plastico	
				Standard bottle for used oil			
4	●	-	X	F002DG14E4	Verschlussstopfen	Bouchon	
					Plug	Tapon	
				For unused connector			

Pos.	Class	Intervall	Customer	Partnumber	BEZEICHNUNG (de)	IDENTIFICATION (fr)	Drawing
					IDENTIFICATION (en)	IDENTIFICACION (es)	
					Kommentar (de)	Comment (en)	
1	●	-	X	F002DG1462	Kunststoffbehälter	Conteneur Plastique	
					Plastic Container	Recipiente De Plastico	
				UV dye expert bottle			
2	●	-	X	F002DG1459	Kunststoffbehälter	Conteneur Plastique	
					Plastic Container	Recipiente De Plastico	
				PAG ISO 46 oil expert bottle			
3	●	-	X	F002DG1500	Anpass-Set	Lot D'adaptation	
					Adapter Kit	juego de adaptador	
				Adapter for expert bottles			
4	●	-	X	F002DG14E4	Verschlussstopfen	Bouchon	
					Plug	Tapon	
				For unused connector			

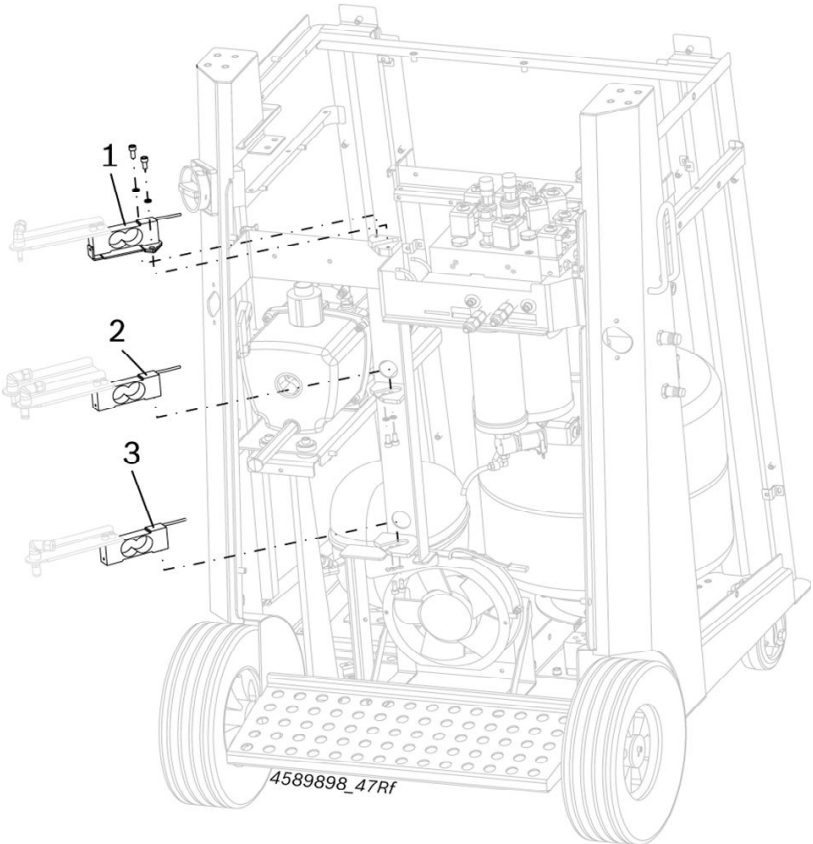
Pos.	Class	Intervall	Customer	Partnumber	BEZEICHNUNG (de)	IDENTIFICATION (fr)	Drawing
					IDENTIFICATION (en)	IDENTIFICACION (es)	
					Kommentar (de)	Comment (en)	
1	●	-	-	F002DG1613	Waage	Balance	
					Balance	Balanza	
					For UV dye bottle, with connector		
2	●	-	-	F002DG1612	Waage	Balance	
					Balance	Balanza	
					For fresh oil bottle, with connector		
3	●	-	-	F002DG1614	Waage	Balance	
					Balance	Balanza	
					For used oil bottle, with connector		

Pos.	Class	Intervall	Customer	Partnumber	BEZEICHNUNG (de)	IDENTIFICATION (fr)	Drawing
					IDENTIFICATION (en)	IDENTIFICACION (es)	
					Kommentar (de)	Comment (en)	
1	●	-	-	F002DG1615	Netzteilplatte	Plaque bloc d'alimentatio	
					Power Supply Board	Circuito impreso adaptado	
					SMPS		
2	●	-	-	F002DG1616	Leiterplatte	Circuit Imprime	
					Printed Circuit Board	Tarjeta Circ Impreso	

Pos.	Class	Intervall	Customer	Partnumber	BEZEICHNUNG (de)	IDENTIFICATION (fr)	Drawing
					IDENTIFICATION (en)	IDENTIFICACION (es)	
					Kommentar (de)	Comment (en)	
1	1	-	-	F002DG1623	Kabelbaum	Faisceau De Cables	
					Wiring Harness	Mazo De Cables	
2	1	-	-	F002DG1629	Kabelbaum	Faisceau De Cables	
					Wiring Harness	Mazo De Cables	
3	1	-	-	F002DG1628	Kabelbaum	Faisceau De Cables	
					Wiring Harness	Mazo De Cables	
4	1	-	-	F002DG1647	Kabelbaum	Faisceau De Cables	
					Wiring Harness	Mazo De Cables	
5	1	-	-	F002DG1620	Kabelbaum	Faisceau De Cables	
					Wiring Harness	Mazo De Cables	
6	1	-	-	F002DG1645	Leistungskabel	Câble de puissance	
					Power Cable	cable p.energía electr.	
7	1	-	-	F002DG1648	Kabelbaum	Faisceau De Cables	
					Wiring Harness	Mazo De Cables	
8	1	-	-	F002DG1646	Verbindungsleitung	Cable De Connexion	
					Connecting Cable	Cable De Conexion	
9	1	-	-	F002DG1621	Kabelbaum	Faisceau De Cables	
					Wiring Harness	Mazo De Cables	
10	1	-	-	F002DG1622	Kabelbaum	Faisceau De Cables	
					Wiring Harness	Mazo De Cables	

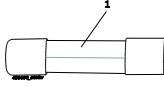
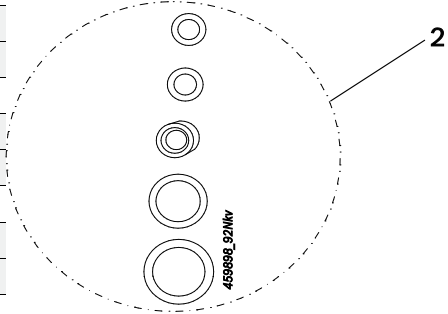
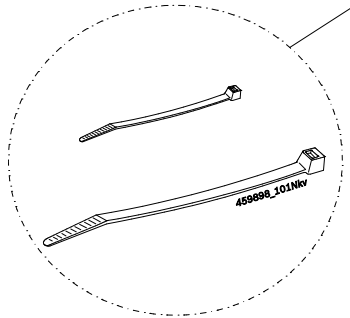

Pos.	Class	Intervall	Customer	Partnumber	BEZEICHNUNG (de)	IDENTIFICATION (fr)	Drawing
					IDENTIFICATION (en)	IDENTIFICACION (es)	
					Kommentar (de)	Comment (en)	
1	●	-	X	F002DG1407	Schlauch	Tuyau	
					Hose	Manguera	
					Set of HP and LP hoses, 3 m		
1*	●	-	X	F002DG1458	Schlauch	Tuyau	
					Hose	Manguera	
					* - Set of HP and LP hoses, 6 m		
2	●	-	X	F002DG1544	Filtersatz	Jeu De Filtres	
					Filter Set	Juego De Filtros	
					Inline filters, 10 pieces		
3	●	-	X	F002DG1406	Kupplungsstück	Piece D'accouplement	
					Coupling	Pieza De Acoplamiento	
					Set of HP and LP couplings		
4	●	-	X	F002DG1649	Anpass-Set	Lot D'adaptation	
					Adapter Kit	juego de adaptador	
					Adapter for external refrigerant bottle		
5	●	-	X	F002DG14F5	Spülventil	Soupape De Balayage	
					Flushing Valve	Valvula De Lavado	
					Adapter for flushing		

Pos.	Class	Intervall	Customer	Partnumber	BEZEICHNUNG (de)	IDENTIFICATION (fr)	Drawing
					IDENTIFICATION (en)	IDENTIFICACION (es)	
					Kommentar (de)	Comment (en)	
1	●	-	X	F002DG1579	Sicherung	Coupe-Circuit	 1
					Fuse	Cortacircuito Fusible	
					Fuse, 230 V, 6.3 A		
2	●	-	X	F002DG1585	Schutzhülse	Manchon De Protection	 2
					Protection Sleeve	Vaina Protectora	
					Set of 10 pieces		
3	●	-	X	F002DG1597	Kabelbinder	Collier De Cable	 3
					Cable tie	Atadura Plast P Cable	
					Set of 3 different sizes of ties		

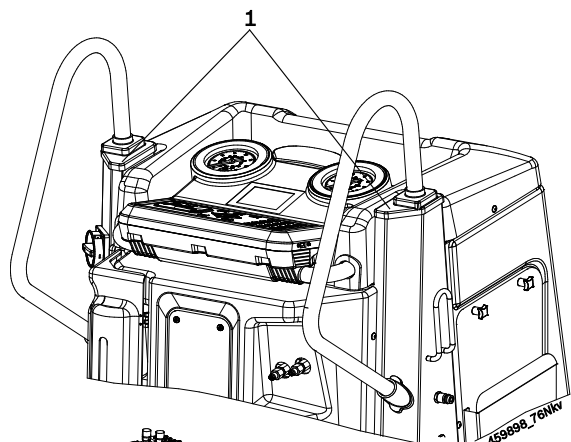
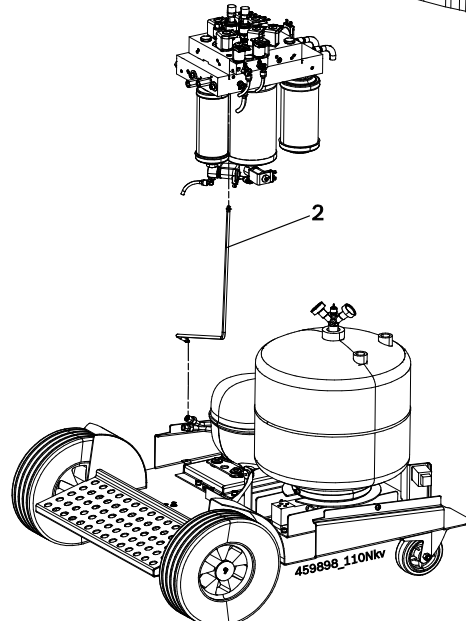
Pos.	Class	Intervall	Customer	Partnumber	BEZEICHNUNG (de)	IDENTIFICATION (fr)	Drawing
					IDENTIFICATION (en)	IDENTIFICACION (es)	
					Kommentar (de)	Comment (en)	
1	○	-	X	F002DG14A7	Kantenschutz	Bordure De Protection	
					Corner Protection	Cubrecantos	
					Set for RH and LH sides		
2	●	-	-	F002DG14A9	Kupferrohr	Tube En Cuivre	
					Copper Tubing	Tubo De Cobre	

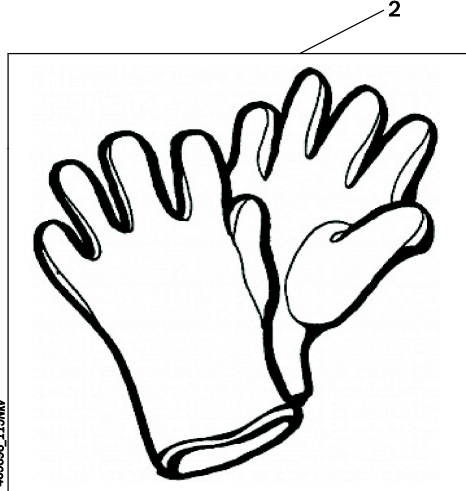
Pos.	Class	Intervall	Customer	Partnumber	BEZEICHNUNG (de)	IDENTIFICATION (fr)	Drawing		
					IDENTIFICATION (en)	IDENTIFICACION (es)			
					Kommentar (de)	Comment (en)			
1	○	-	X	F002DG14G7	Schutzbrille	Lunettes De Protection			
					Protective Goggles	Gafas Protectoras			
2	○	-	X	F002DG14G8	Handschuhe	Gants			
					Gloves	guantes			

Pos.	Class	Intervall	Customer	Partnumber	BEZEICHNUNG (de)	IDENTIFICATION (fr)	Drawing	
					IDENTIFICATION (en)	IDENTIFICACION (es)		
					Kommentar (de)	Comment (en)		
1	○	-	X	F002DG14G9	Anschraubplatte Screw-On Plate	Plaque A Visser Placa Para Atornillar		

Date	Product	Editor	Modification
------	---------	--------	--------------



Robert Bosch GmbH  
Automotive Service Solutions  
Franz-Oechsle-Str. 4  
73207 Plochingen  
DEUTSCHLAND  
[www.bosch.com](http://www.bosch.com)

1 689 973 374 - 2013-11-12